

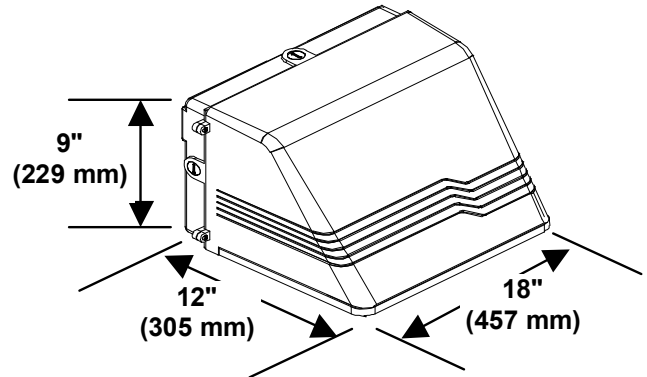

WTZL - Wall pack Trapezoid Large
Metal Halide Pulse Start 200 - 400 W
Metal Halide 250 - 400 W
High Pressure Sodium 250 - 400 W
LED 2 - 3 x 15 W



DESCRIPTION

The WTZL is an architectural grade full cutoff wall pack for up to 400W HID lamps or LED 3 x 15W lamps. Fully Dark Sky compliant. U.L. listed for wet locations.

APPLICATION

Ideal for security lighting around commercial, industrial and residential buildings where limiting glare and light trespass are important while maintaining an aesthetically appealing dayform appearance.

Can also be used as an uplight for accent lighting of facades.



HOUSING

The housing is made of high pressure die cast aluminum and finished in a dark bronze polyester powder coat paint finish for lasting corrosion resistance.

BALLAST

High Power Factor, Constant Wattage Autotransformer ballasts, Multi Tap (120/208/240/277V). Minimum starting temperature is -20°F (-30°C) for MP and MH, -40°F (-40°C) for HPS. Multi Tap, electronic drivers for LED.

SOCKET

Mogul base, 4KV pulse rated porcelain socket for HID.

MOUNTING

Knockout pattern provided on back casting for mounting to junction boxes. Three 1/2" threaded entry hubs provided for top or side conduit wiring and through wiring.

REFLECTOR

Die formed, anodized aluminum.

GASKET

Silicone rubber for long life.

LENS

Flat borosilicate glass, impact and heat resistant.

CATALOG NUMBER LOGIC

WTZL-

Product Series
 WTZL = Wall pack Trapezoid Large

MP

Lamp Type
 MP = Metal Halide Pulse Start
 MH = Metal Halide
 HP = High Pressure Sodium
 LD = LED

400-

Lamp Wattage
 (MP) 200, 250, 320, 350, 400
 (MH) 250, 400
 (HPS) 250, 400
 (LED) 215 = 2 x 15W
 315 = 3 x 15W

MT-

Voltage
 MT = Multi Tap
 120/208/240/277V
 480V = 480V

L

Lamp
 L = Lamp Included